

TS 60N02

N-Channel Enhancement Mode Power Mosfet

DRAWING

Features

- ◆ 20A,60V, $R_{DS(ON)} < 45m\Omega @ V_{GS}=10V$
- ◆ Special process technology for high ESD capability
- ◆ High density cell design for ultra low R_{dson}
- ◆ Fully characterized Avalanche voltage and current
- ◆ Good stability and uniformity with high E_{as}
- ◆ Excellent package for good heat dissipation

General Description

- ◆ Package:TO-220C
- ◆ The TS6020 uses advanced trench technology and design to provide excellent T_{dson} with low gate charge. It can be used in a wide variety of applications.

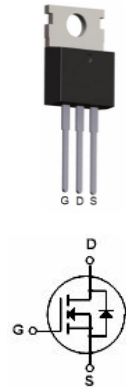

Absolute Maximum Ratings ($T_c=25^\circ C$ unless otherwise noted)

Symbol	Parameter	Spec	Units
V_{DSS}	Drain-Source Voltage	60	V
V_{GSS}	Gate-Source Voltage	± 20	V
I_D	Drain Current -Continuous($T_c=25^\circ C$)	20	A
I_D	Drain Current -Continuous($T_c=100^\circ C$)	14	A
I_{DM}	Drain Current -Pulsed	60	A
P_D	Maximum Power Dissipation	100	W
	Derating factor	0.8	W/ $^\circ C$
E_{AS}	Single Pulsed Avalanche Energy(Note5)	72	mJ
T_J, T_{STG}	Operating Junction and Storage Temperature Range	-55 to +175	$^\circ C$
R_{JC}	Thermal Resistance, Junction-to-Case(Note2)	1.25	$^\circ C/W$

Electrical Characteristics ($T_A=25^\circ C$ unless otherwise noted)

Off Characteristics

Symbol	Parameter	Test Conditions	Min	Typ	Max	Units
BV_{DSS}	Drain-Source Breakdown Voltage	$V_{GS}=0V, I_D=250\mu A$	60		-	V
I_{DSS}	Zero Gate Voltage Drain Current	$V_{DS}=60V, V_{GS}=0V$	-	-	1	μA
I_{GSS}	Gate-Body Leakage Current,	$V_{GS}=\pm 20V, V_{DS}=0V$	-	-	± 100	nA

On Characteristics (Note3)

Symbol	Parameter	Test Conditions	Min	Typ	Max	Units
$V_{GS(th)}$	Gate Threshold Voltage	$V_{DS}=V_{GS}, I_D=250\mu A$	1.2	2.0	3.0	V
$R_{DS(ON)}$	Static Drain-Source On-Resistance	$V_{GS}=10V, I_D=20A$	-	37	45	m Ω
g_{FS}	Forward Transconductance	$V_{DS}=5V, I_D=4.5A$	11	-	-	S

Dynamic Characteristics (Note4)

Symbol	Parameter	Test Conditions	Min	Typ	Max	Units
Cjss	Input Capacitance	VDS=30V,	—	500		PF
Coss	Output Capacitance	VGS=0V,	—	60		PF
Crss	Reverse Transfer Capacitance	f=1.0MHz	—	25		PF

Switching Characteristics (Note4)

Symbol	Parameter	Test Conditions	Min	Typ	Max	Units
t _{don}	Turn-On Delay Time	V _{DD} =30V, I _D =2A R _G =3Ω R _L =6.7Ω	—	5	—	ns
t _r	Turn-On Rise Time		—	2.6	—	ns
t _{doff}	Turn-Off Delay Time		—	16.1	—	ns
t _f	Turn-Off Fall Time	VGS=10V	—	2.3	—	ns
Q _g	Total Gate Charge	V _{DS} =30V	—	14	—	nc
Q _{gs}	Gate-Source Charge	I _D =4.5A	—	2.9	—	nc
Q _{gd}	Gate-Drain Charge	V _{GS} =10V	—	5.2	—	nc

Drain-Source Diode Characteristics and Maximum Ratings

Symbol	Parameter	Test Conditions	Min	Typ	Max	Units
I _s	Diode forward current (Note3)		—	—	20	A
V _{sd}	Drain-source diode forward Voltage (Note2)	VGS=0V, I _S =20A	—	—	1.2	V
T _{rr}	Reverse Recovery Time	T _J =25°C, I _F =20A	—	35		ns
Q _{rr}	Reverse Recovery charge	di/dt=100A/us (Note3)	—	53		uc
T _{on}	Forward Turn-On Time	Intrinsic turn-on time is negligible(turn-on is dominated by LS+LD)				

Notes:

- 1.Repetitive Rating: Pulse width limited by maximum junction temperature.
- 2.Surface Mounted on FR4 Board, t≤10 sec
- 3.Pulse Test: Pulse Width ≤300us, Duty cycle≤2%
- 4.Guaranteed by design, not subject to production
- 5.EAS condition: T_J=25°C, V_{DD}=30V, V_G=10V, L=0.5mH, R_G=25Ω

Test circuits

1)EAS Test Circuits

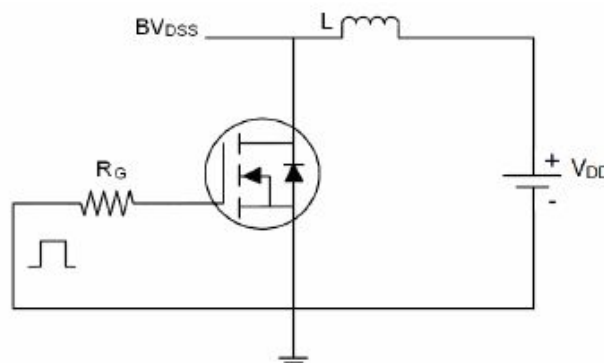

2) Gate Charge Test Circuit

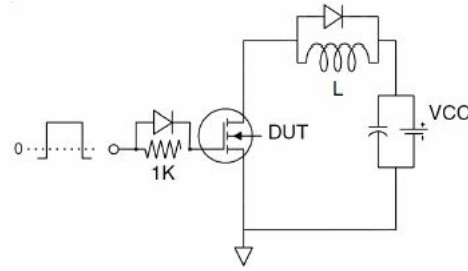

3) Switch Time Test Circuit

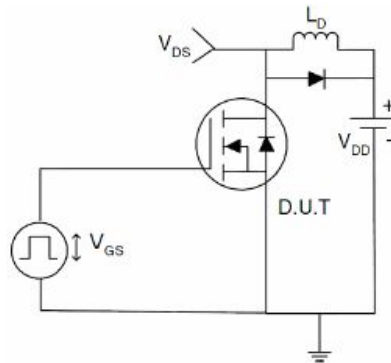

Typical Electrical And Thermal Characteristics(Curves)

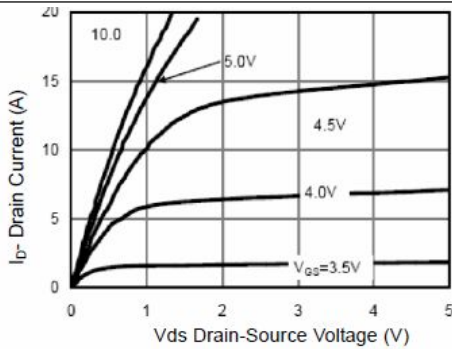

Figure 1 Output Characteristics

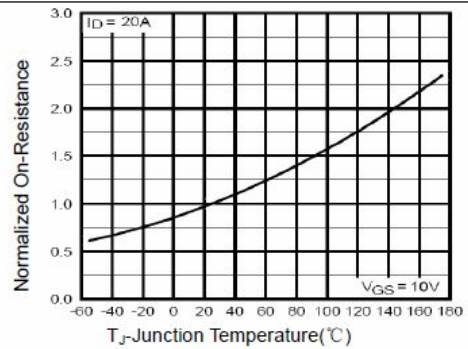

Figure 4 Rds(on)-Junction Temperature

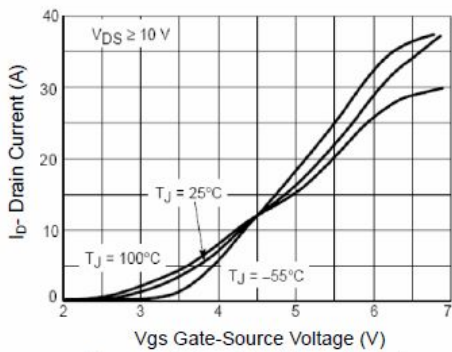

Figure 2 Transfer Characteristics

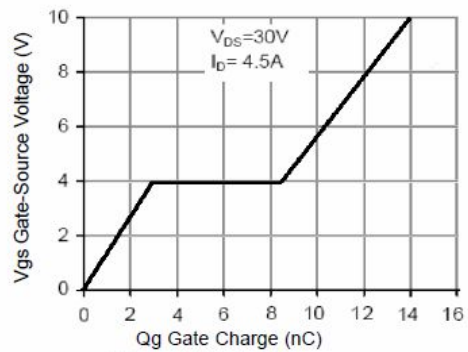

Figure 5 Gate Charge

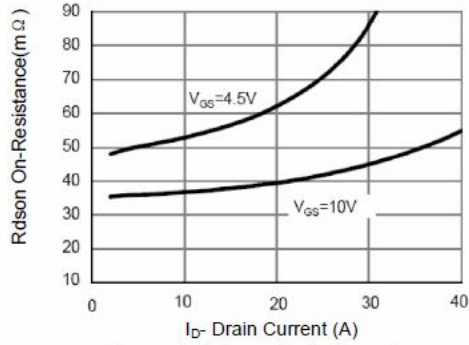

Figure 3 Rdson- Drain Current

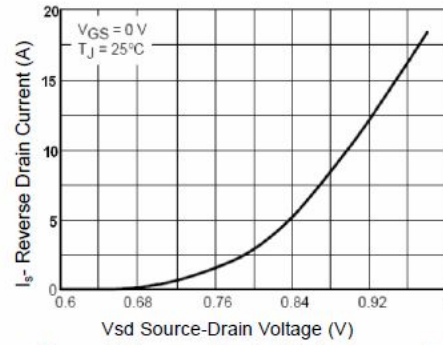

Figure 6 Source- Drain Diode Forward

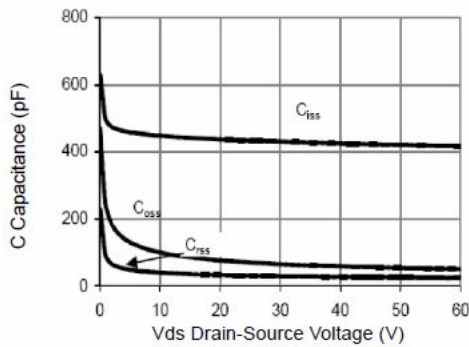

Figure 7 Capacitance vs Vds

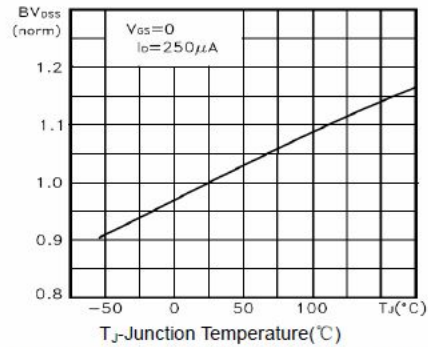

Figure 9 BV_{DSS} vs Junction Temperature

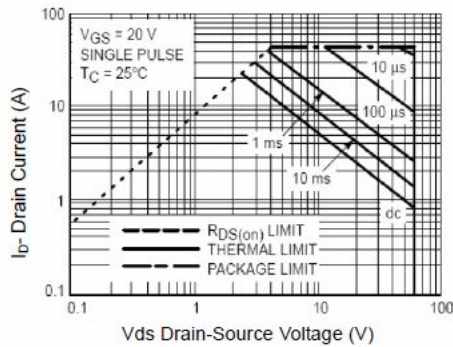

Figure 8 Safe Operation Area

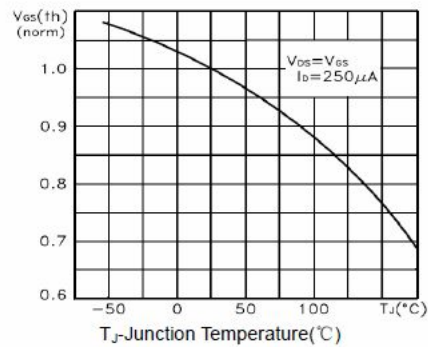

Figure 10 V_{GS(th)} vs Junction Temperature

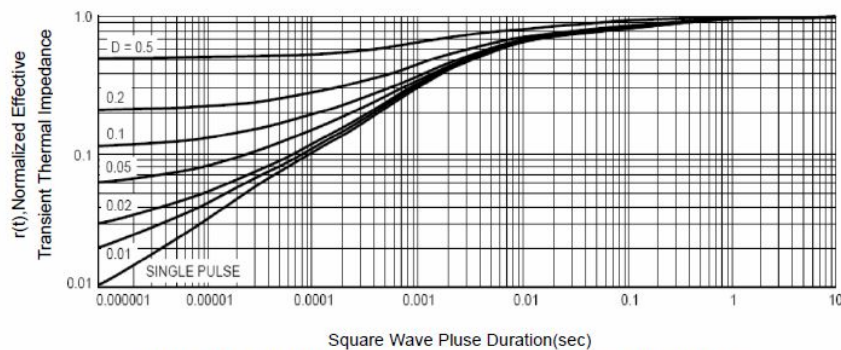

Figure 11 Normalized Maximum Transient Thermal Impedance

Mechanical Dimensions

